

Part 6

Assembling the Y axis

In this section you will assemble the Y axis which carries the heated bed.

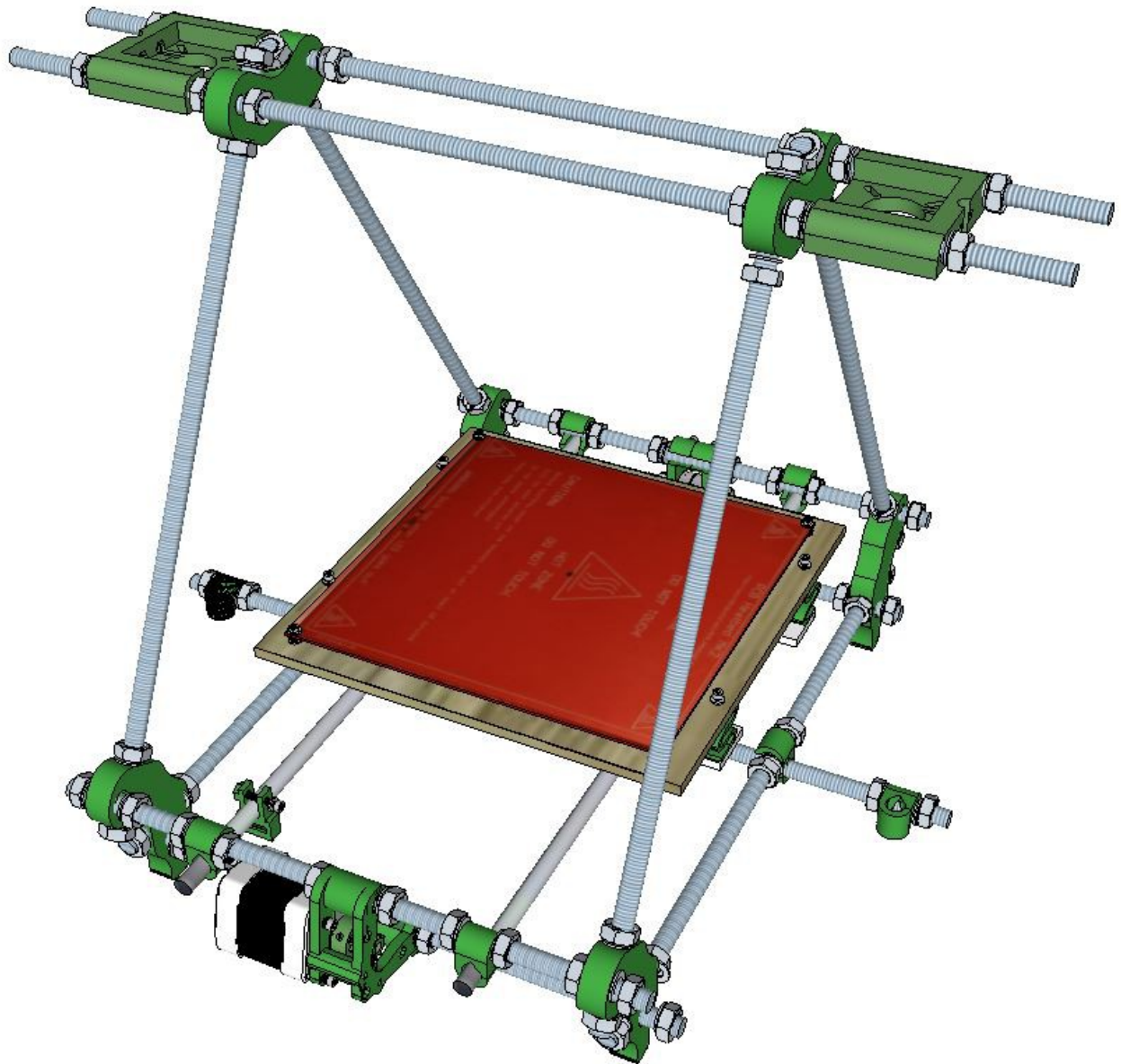

Parts

You will need the following parts;

- 4 x printed bed springs
- 2 x printed Y motor brackets
- 2 x Y idler brackets
- 2 x printed belt clamps (these are larger than those for the X carriage)
- 1 x printed pulley
- 1 x printed end stop holder
- 1 x Acrylic axis plate
- 1 x plywood carrier plate
- 1 x red heated bed
- 3 x LM8UU linear bearings
- 2 x 608 skate bearings
- 1 x end stop microswitch
- 3 x cable ties
- 1 x M8x40 hex bolt
- 3 x M3x10 cap screws
- 11 x M3x20 cap screws
- 2 x M3x30 cap screws
- 4 x M3x45 cap screws
- 40 x M3 washers
- 4 x M8 washers
- 1 x M8 nut
- 22 x M3 nuts
- 4 x M3 Nyloc nuts
- 1 x M3 grub screw

Preparation

The first part of this section describes the preparation of the plywood carrier plate.

Check that the cable ties fit through the slots in the acrylic sheet, ease with a file if necessary.

Most people assemble the electronics and wire up the micro switches before assembling the mechanical components, if you have not followed this sequence then make sure the microswitch will click in to the end stop holder but then carefully ease it out to solder the wires later.

The plastic parts have mostly M3 holes and one M8 holes, ease these for cap screws and bolt as before using a file and/or drill bit.

The pulley has a nut trap into which an M3 nut must be slotted to support a grub screw. Ease this slot using a file or if brave you can use a soldering iron to heat and push a nut in to the slot. You must make sure the hole in the nut aligns with that in the plastic and that you are able to extract the nut if the fit isn't quite right.

The tooth drive belt may have been supplied to you as a single length. You will need to cut it so there is sufficient belt for both the X and Y axes, so measure many times as you can only cut once.

1

The major part of the Y axis is made up of a set of plates, the heated bed (red PCB which is bolted onto a plywood plate which is bolted in turn to an acrylic plate and rides on printed springs. The plywood plate should have 8 3mm holes, 4 which align with the holes in the corner of the red PCB and another 4 holes which align with those in the acrylic plate. Check that these holes align properly with each plate and file any which are out of true.

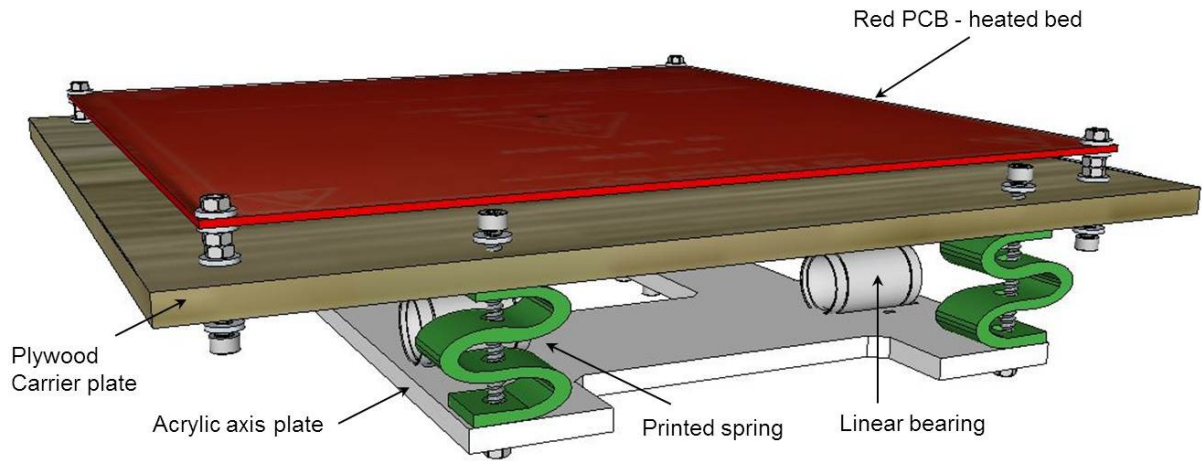

2

If the plywood plate does not have any holes then carefully mark centre points and drill a 3mm hole at each of the four corners using the red PCB corner holes as a template (roughly 8mm inset from each side).



3

If there are no holes in the plywood matching the acrylic base plate then carefully mark centre points and drill a 3mm hole at each of the four corners using the acrylic plate holes as a template.

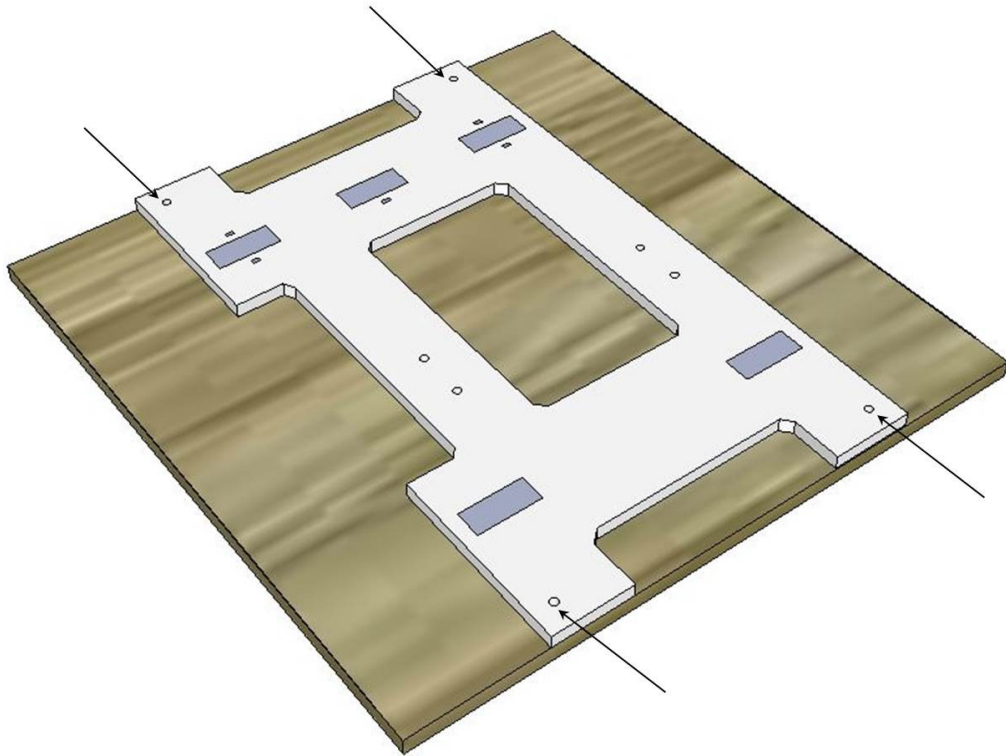

4

Mount three of the linear bearings in the rectangular holes in the acrylic base plate as shown, making sure to mount is the same arrangement relative to the Y axis cutout. Secure the bearings using cable ties fed through the slots either side of the bearing in the acrylic plate

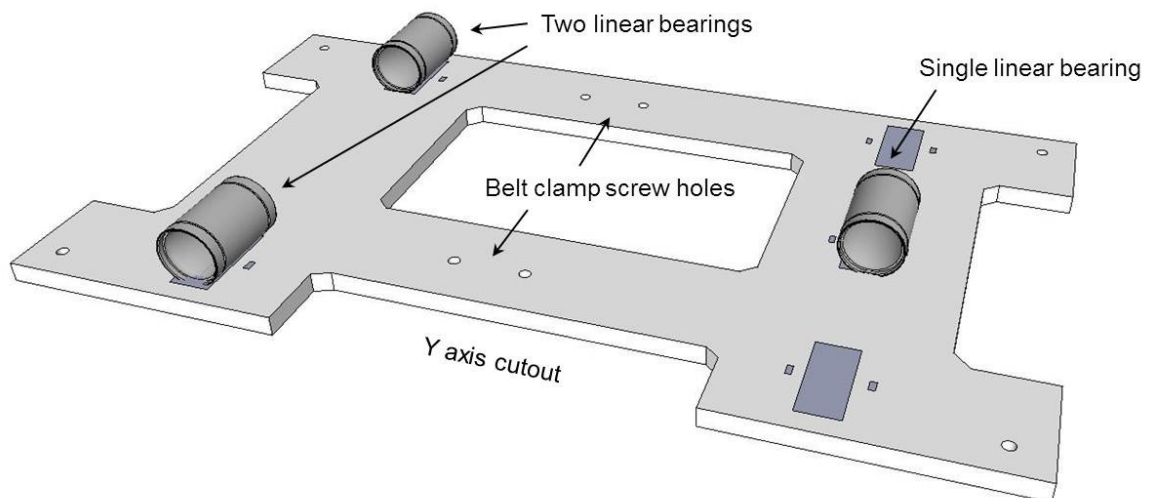

5

Mount the belt clamps as shown, one under the plate and one on top using M3x20 cap screws, washers and nyloc nuts. Nyloc nuts are taller than regular nuts and have a plastic insert. Do not tighten the screws just yet, wait until the plate has been mounted and the drive belt fitted.

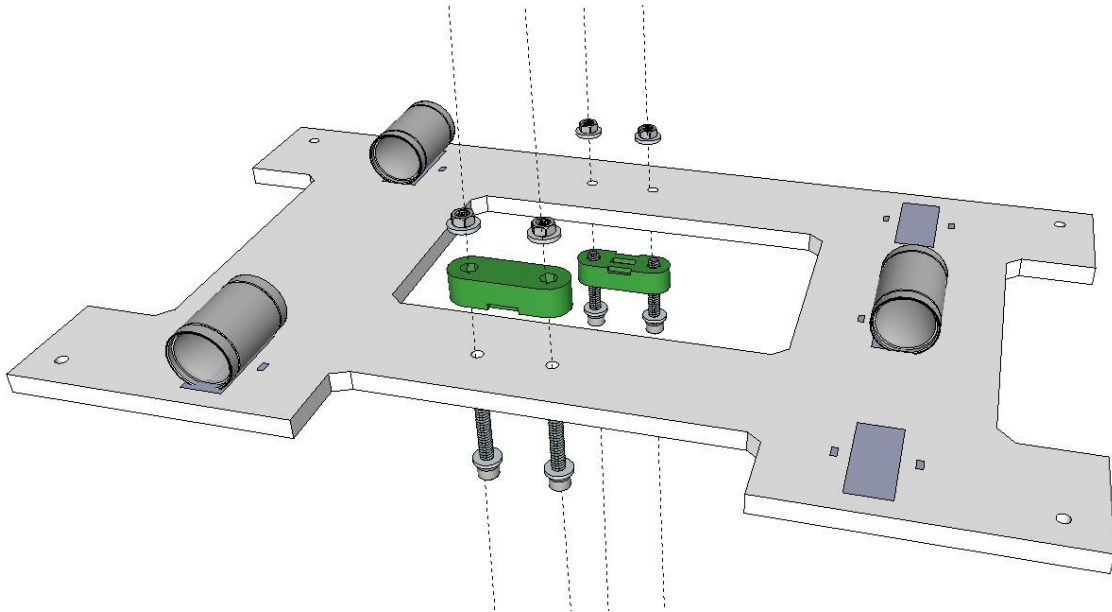

6

Assemble one of the end stops by inserting a wired micro switch into the slot as shown and insert a m3x20 cap screw, washer and nut. Do not tighten the nut yet. Note, ensure the middle terminal and the one at the same end as the red switch are wired (so the switch will make rather than break contact when the red button is pressed) and have heat shrink insulation.

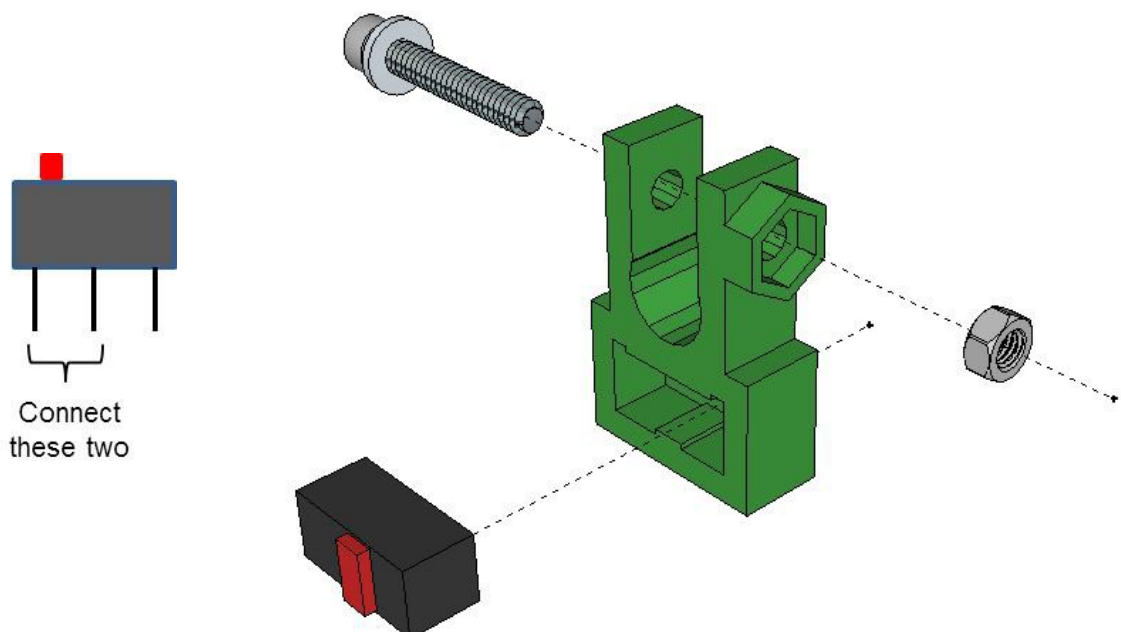

7

Remove the motor and idler brackets from the front and rear threaded rods.

Slide two of the 404 mm smooth rods through the rod clamps at one end of the frame. Mount the acrylic bed as shown, paying attention to the position of the cut out and belt clamps, inserting the smooth rods in to the linear bearings. Push the smooth rods through to the rod clamps at the other end of the frame, sliding the endstop on to the marked rod as you go.

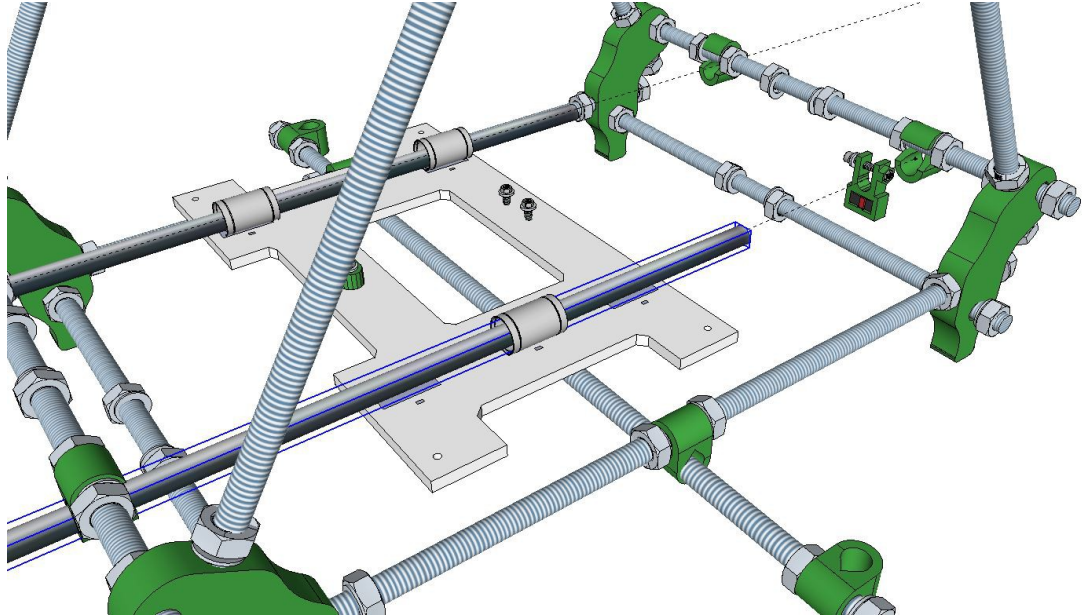

8

Once the rods have been inserted in the opposite rod clamps your frame should look like the picture below. Check that the acrylic bed is positioned as shown with the y axis cut out at one end and the y axis endstop on the smooth rod at the other end.

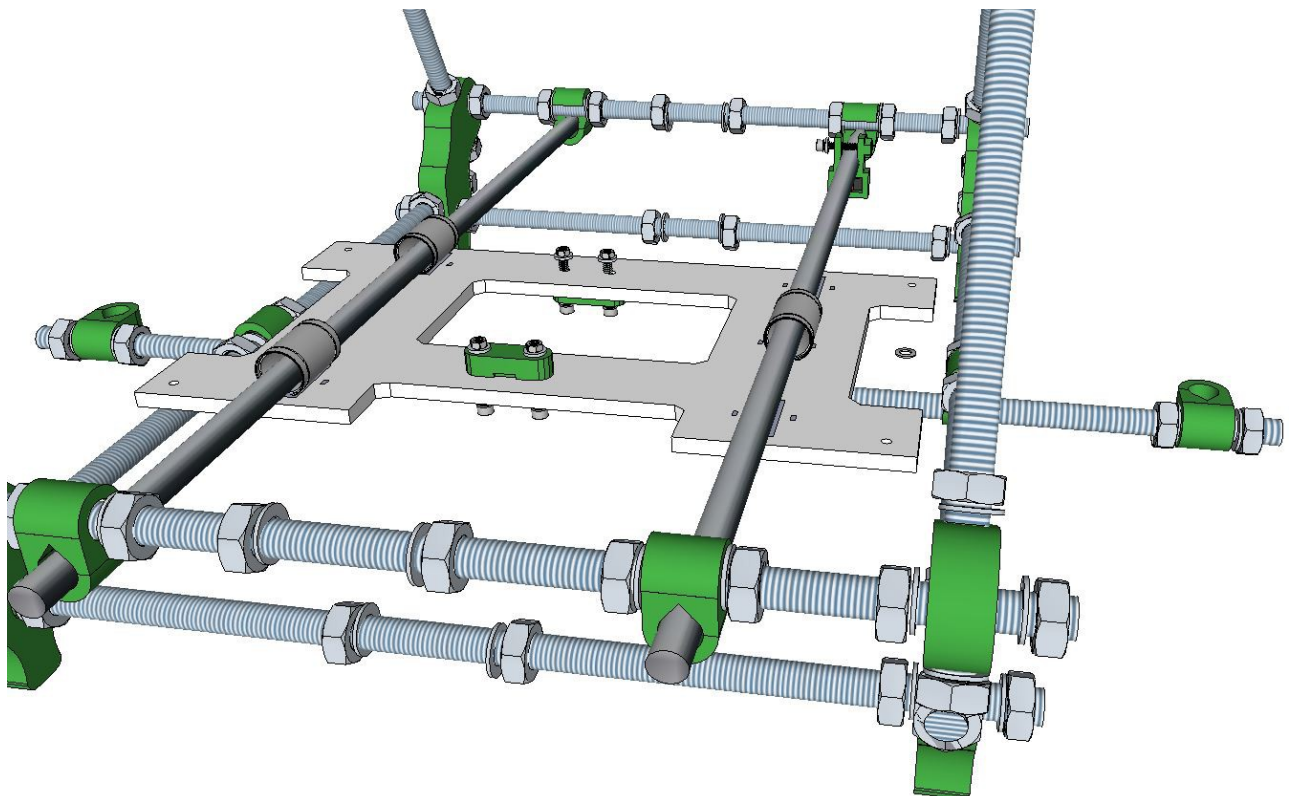

9

Mount the plywood carrier plate on to the acrylic plate using the printed springs, M3x45 cap screws, washers and nyloc nuts.

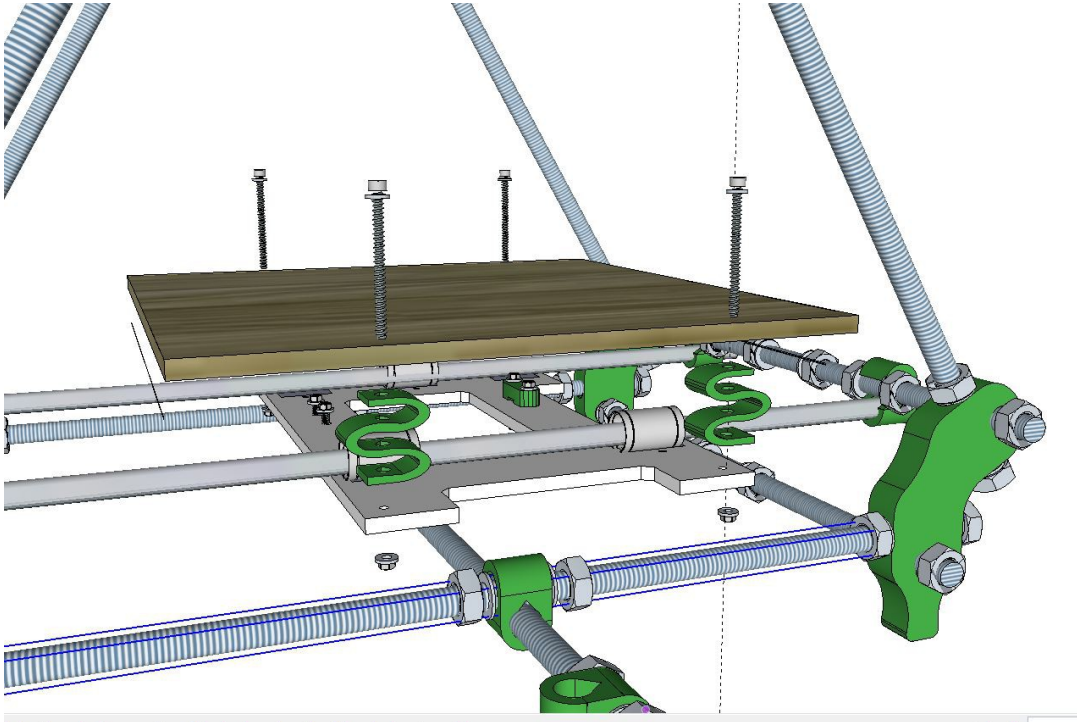

10

Then mount the red PCB hotbed on to the plywood carrier plate using M3x20 cap screws, washers and nuts as shown. Ensure that there are two M3 nuts between the hot bed and carrier plate to ensure enough gap to fit spring clips later on. Position the PCB so the solder points for the wires is to the left or right along the X axis, depending on which side you plan to locate the electronics boards.

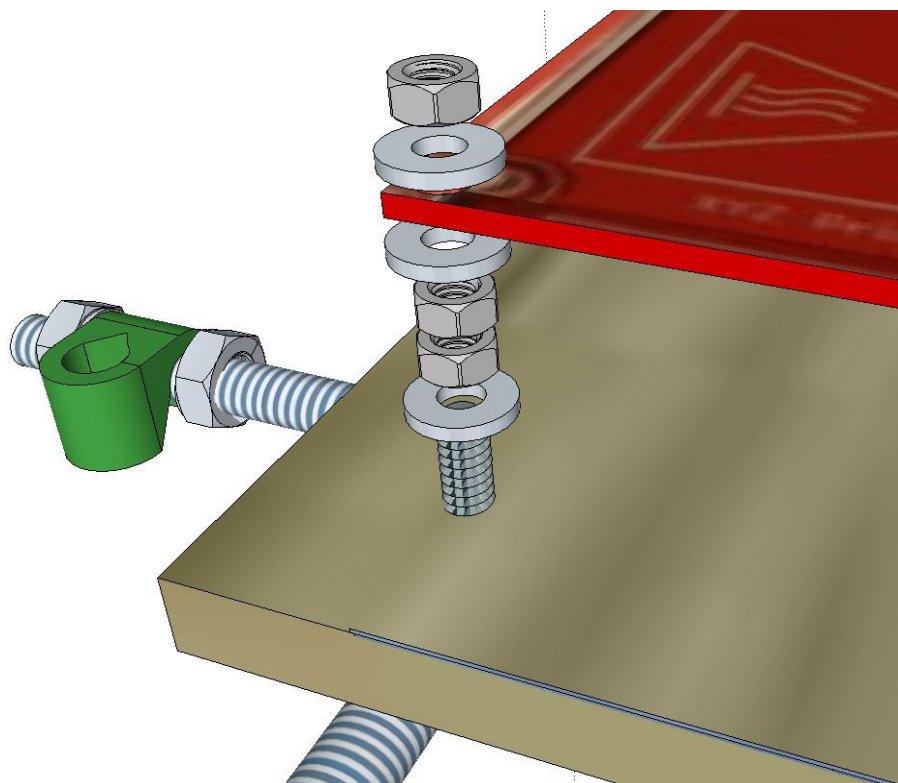

11

Your frame should look like the image below, here the PCB contacts are on the left side.

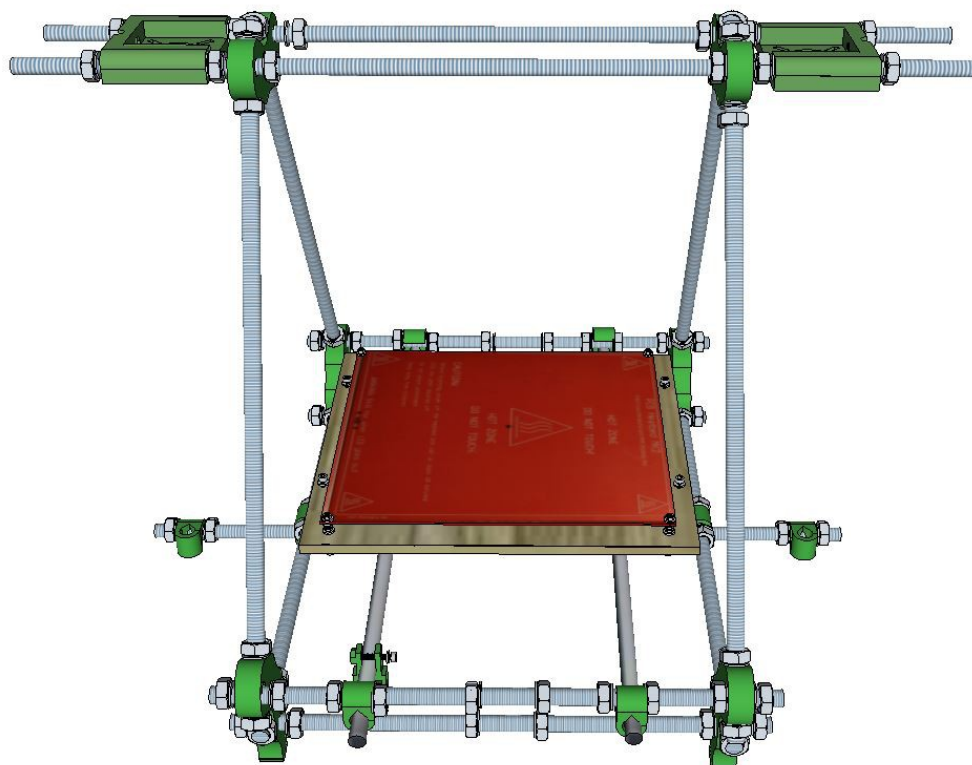

This image shows the underside of the frame so far. Note the relative positions of the acrylic plate and endstop switch. The assembled Y stage should be free to move from one end of the smooth rods to the other (the Y axis) passing between the triangle sections.

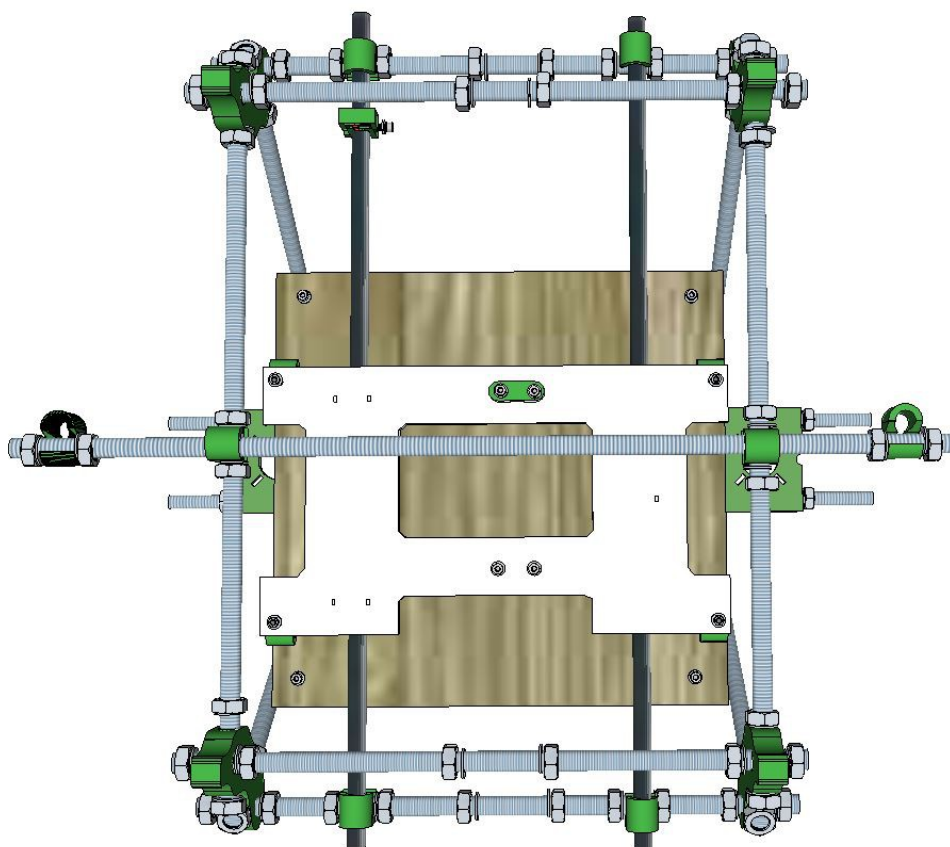

12

You will now construct the Y axis motor sub-assembly. Start by making sure the two halves of the motor bracket are bolted together using two M3x30 cap screws, washers and nuts. Ensure the side with the three larger holes is on the right, these holes are to allow a hex key to pass through to tighten the motor bolts.

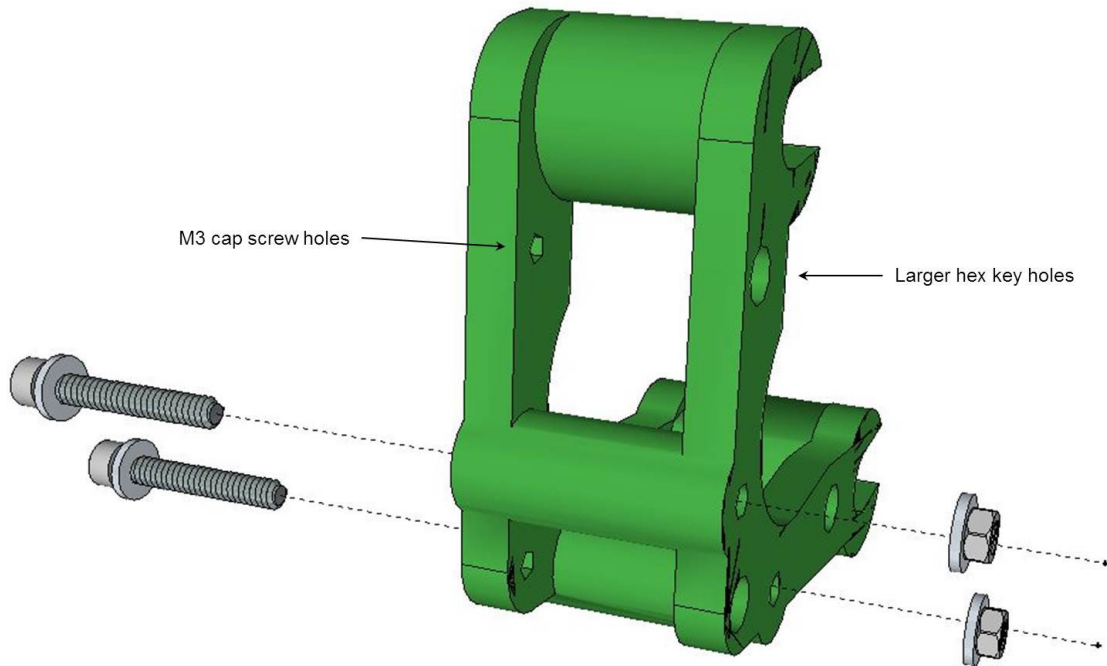

13

Prepare one of the pulleys by inserting an M3 nut in to the captive slot in the base of the pulley and introduce a grub screw into the nut.

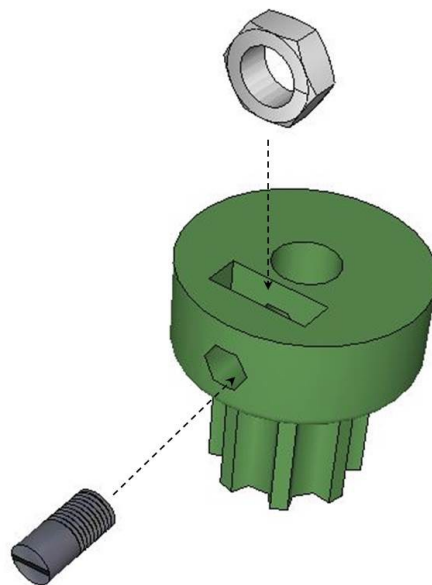

14

Mount the pulley on to the shaft of a stepper motor. Ensure the grub screw screws down perpendicular to the flattened section of the shaft and tighten the grub screw firmly. If the screw is not properly perpendicular or not screwed firmly it will loosen and the Y access will slip during operation causing inaccurate printing.

Mount the motor into the bracket using three M3x10 cap screws and washers.

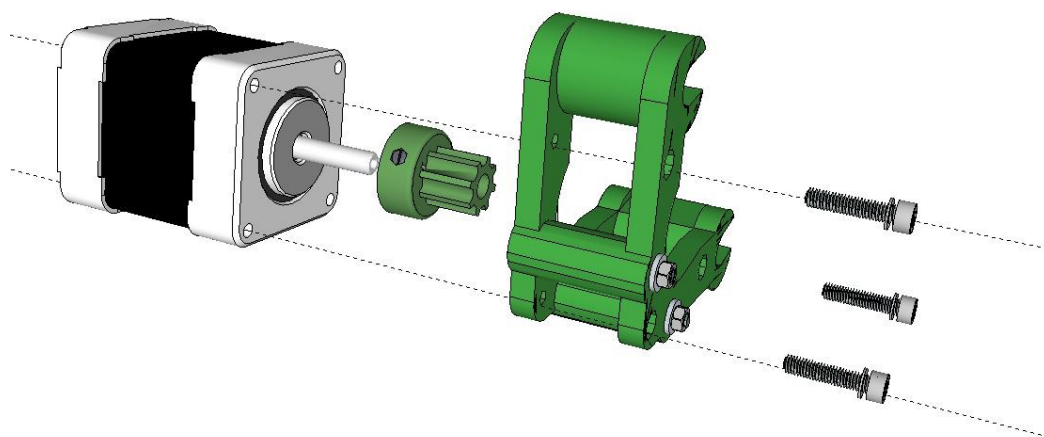

15

Slide the motor bracket sub-assembly onto the threaded rods at the end nearest the Y axis endstop between the two pairs of M8 bolts and washers.

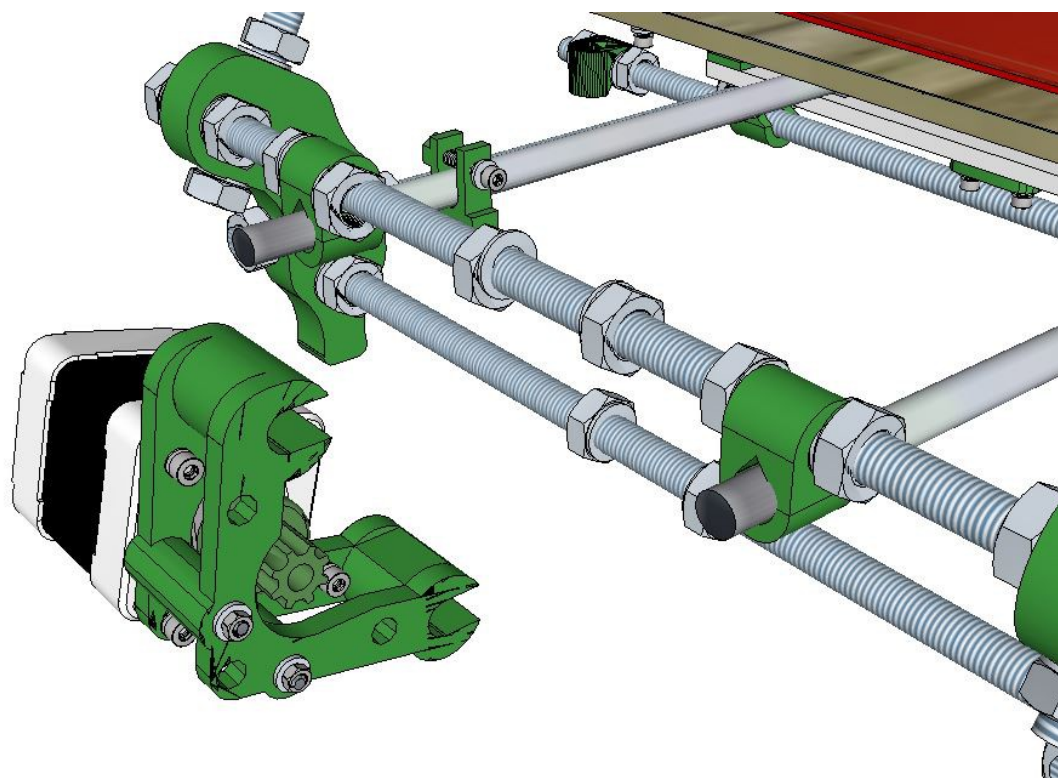

16

loosely tighten the bolts and washers against the motor bracket to hold it in place.

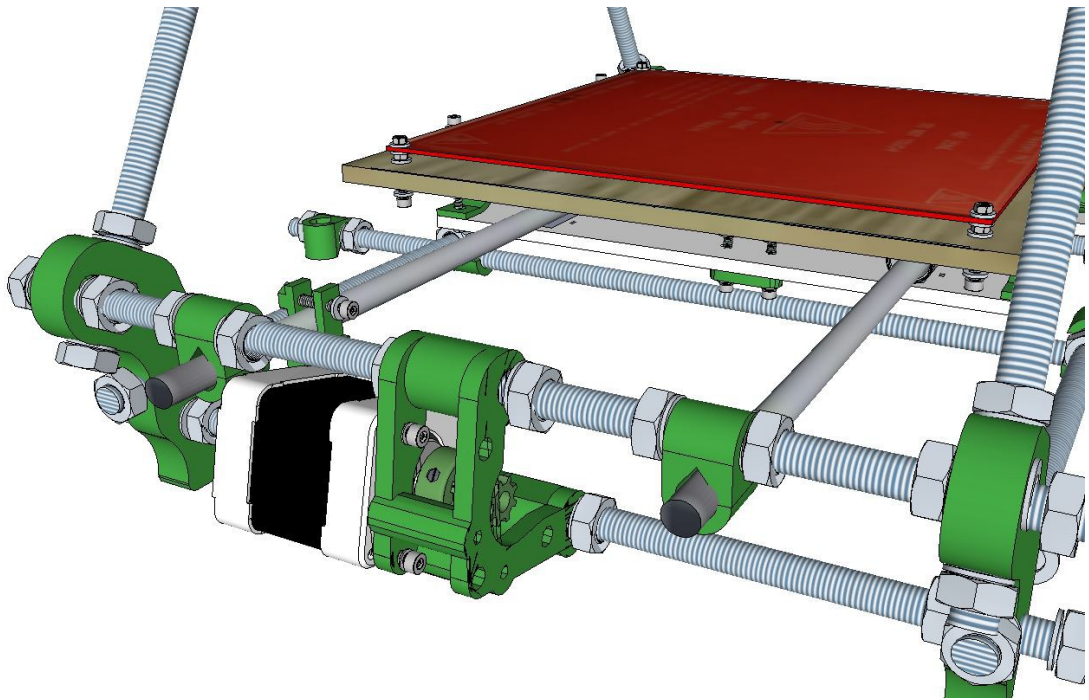

17

You will now construct the Y axis idler sub-assembly. Start by mating the two halves of the motor bracket together with two of the 608 skate bearings,

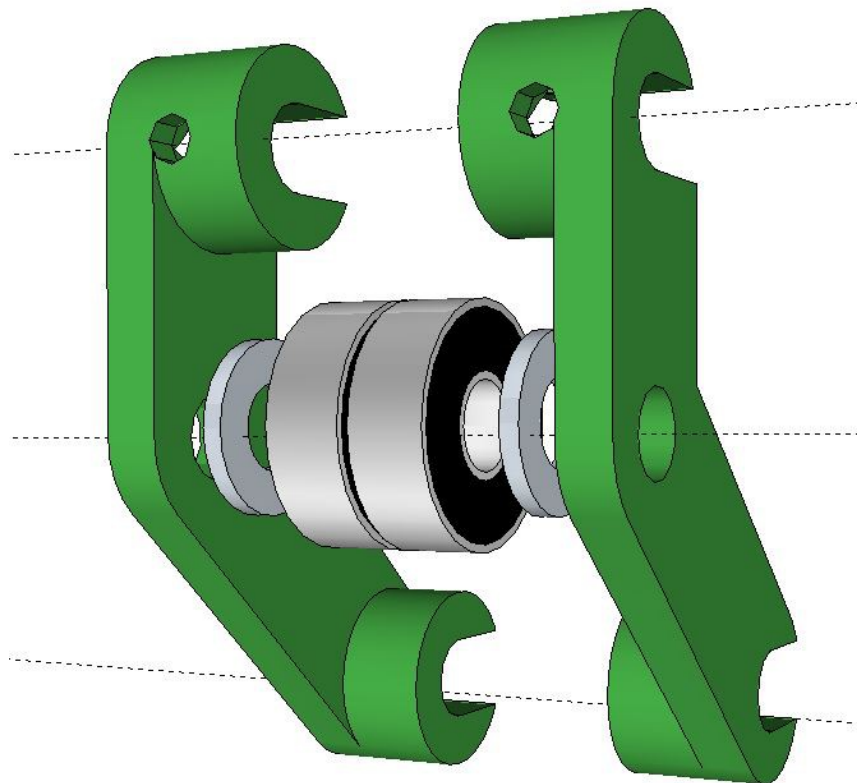

18

Make sure there is an M8 washer between each arm of the bracket and each 608 bearing then slide in a M8x40 hex bolt with washers at each end and an M8 nut. Introduce the two M3x20 cap screws with nuts as shown, these will be used later to tighten the idler against the Y axis drive belt.

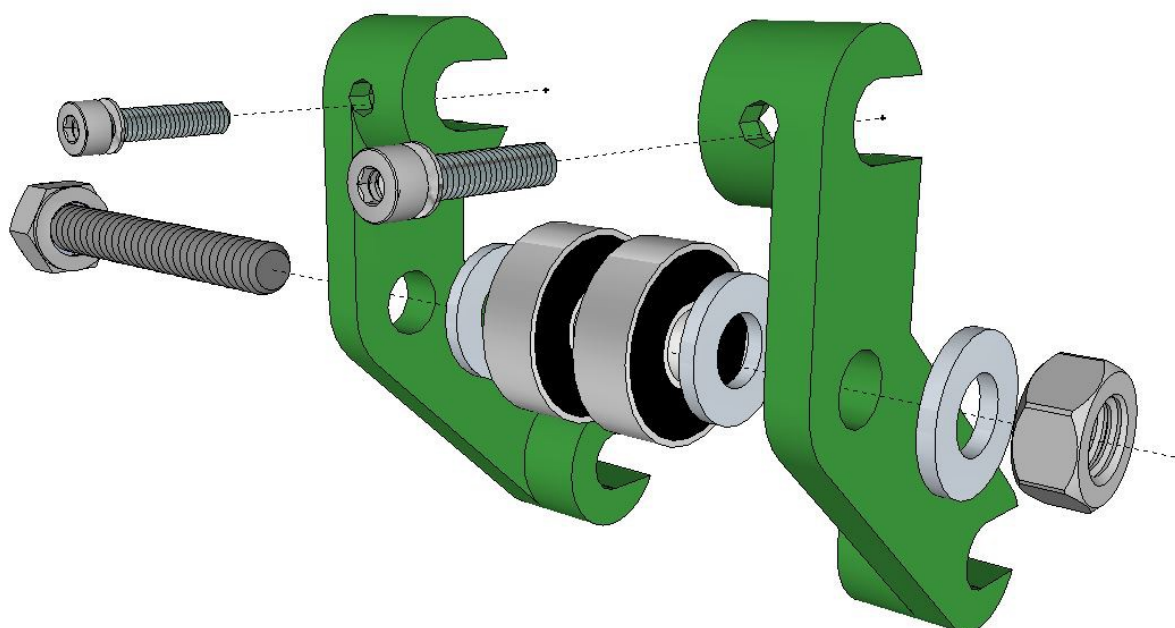

19

Slide the idler bracket sub-assembly onto the threaded rods at the opposite end of the Y axis from the motor bracket between the two pairs of M8 bolts and washers.

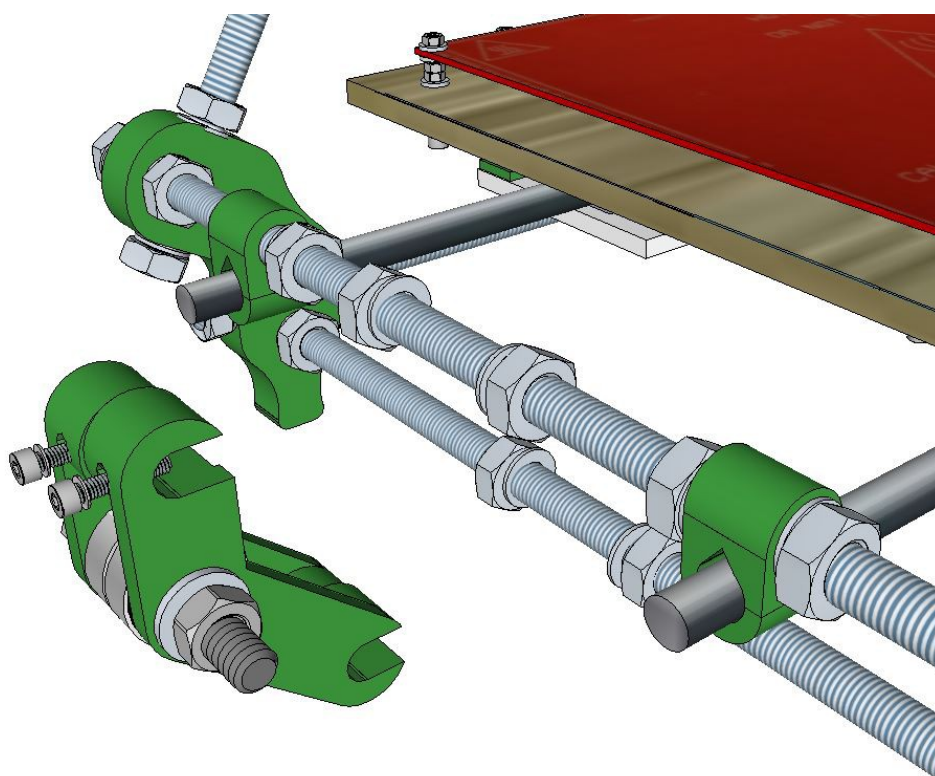

20

loosely tighten the bolts and washers against the idler bracket to hold it in place.

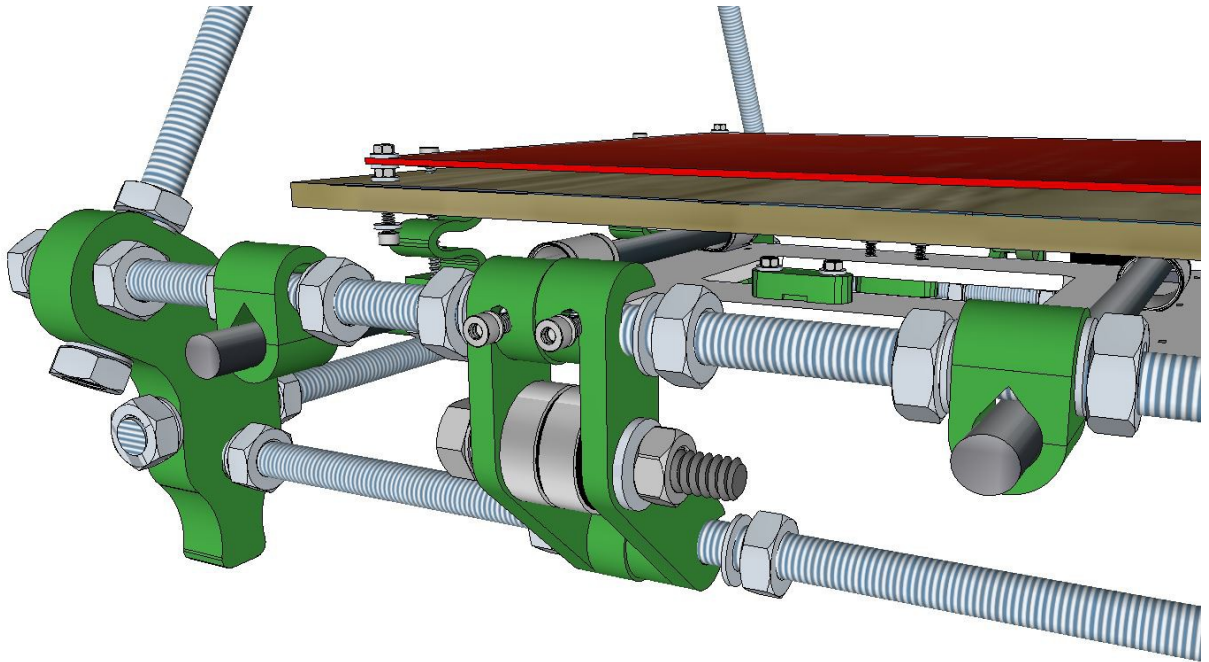

21

Your machine is starting to take shape ...

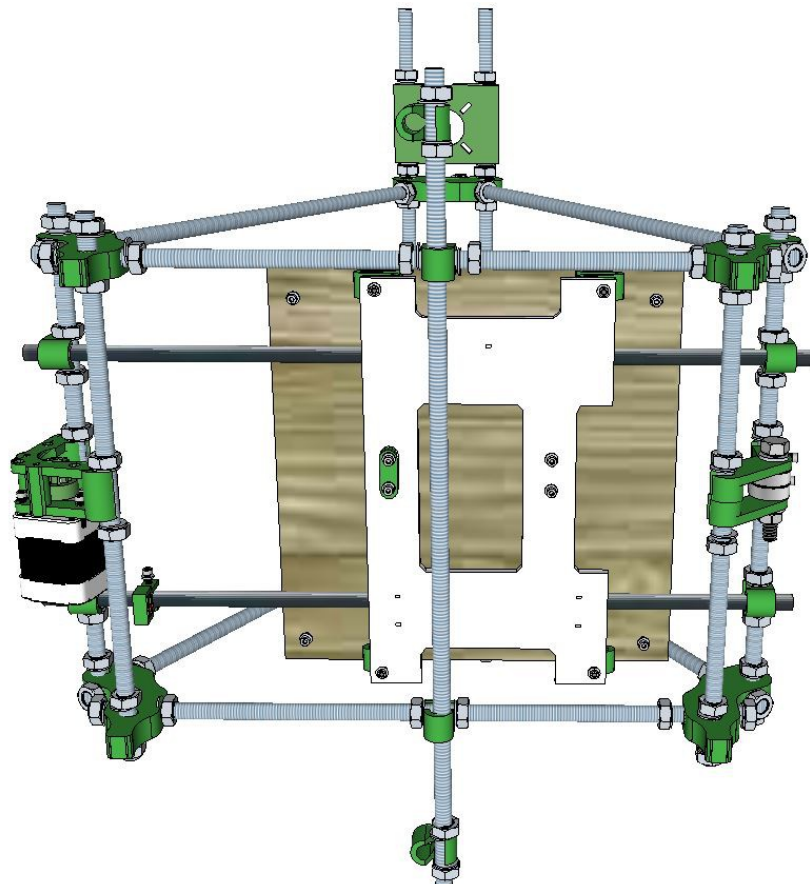

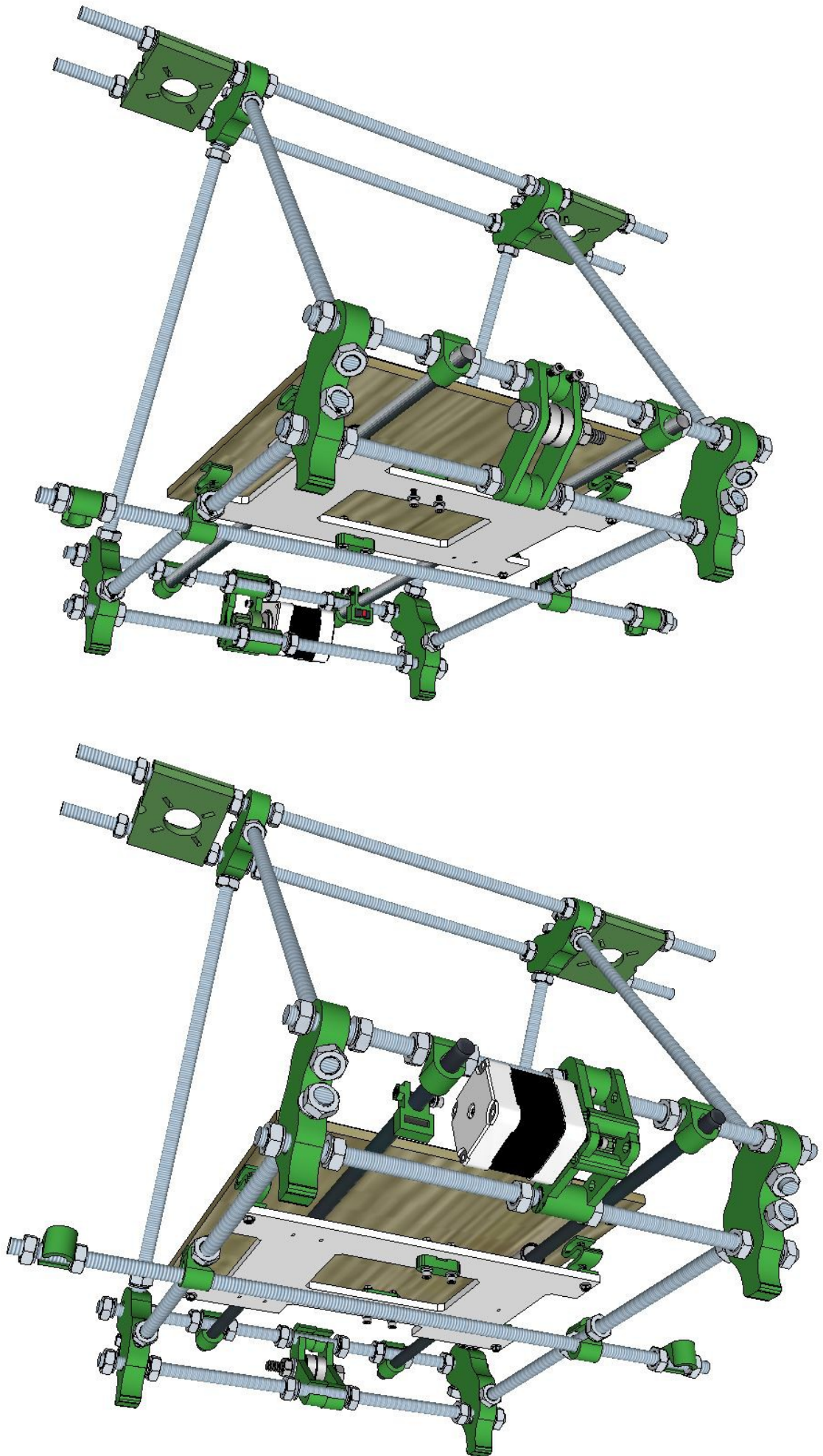

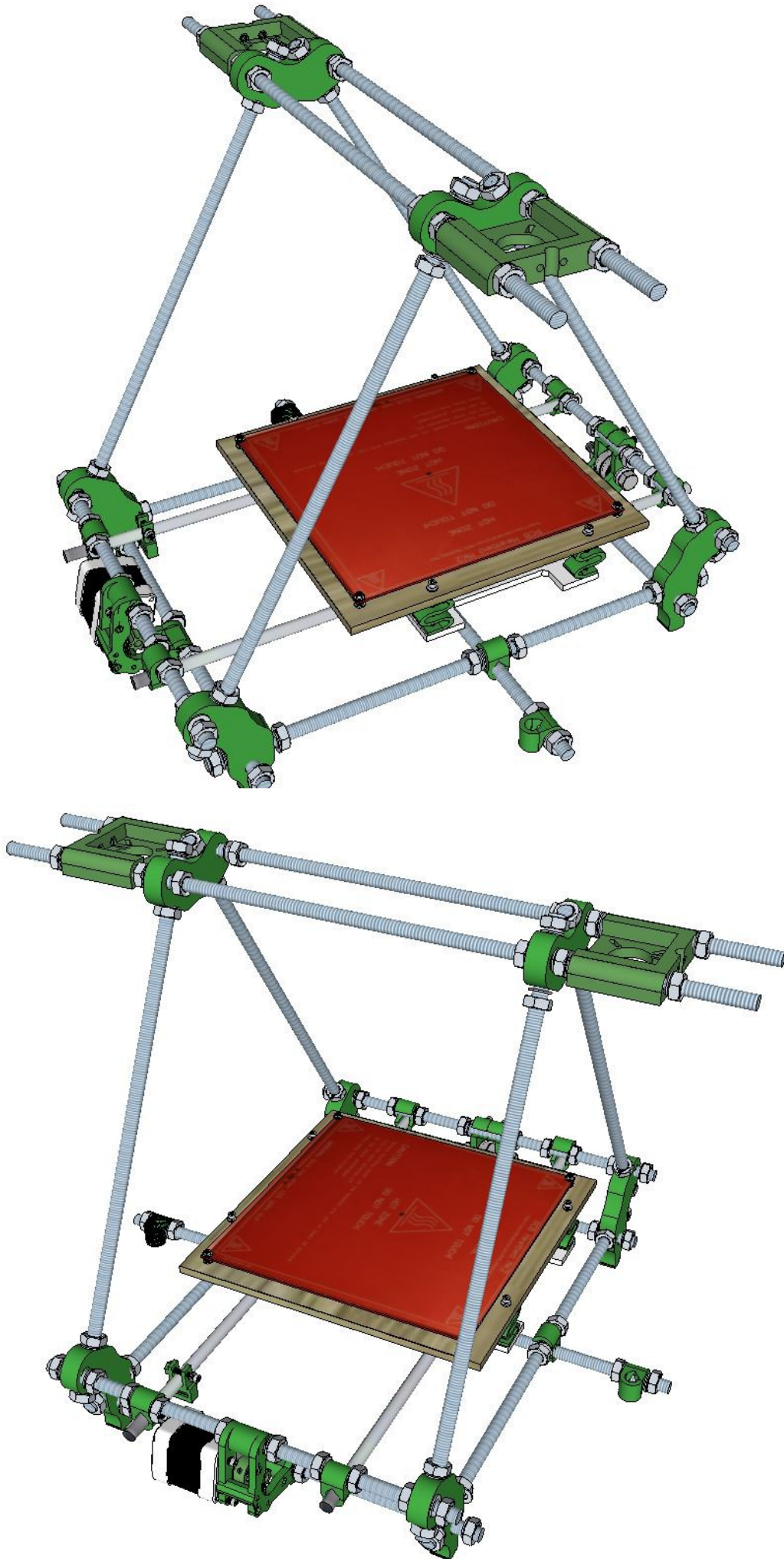

21

The final step is to mount the drive belt. Take off the plywood plate from the acrylic plate.

The belt goes over the drive pulley with the belt teeth engaging the teeth of the pulley. The belt is then twisted once so its smooth side goes over the idler pulley at the opposite end of the Y axis. The two ends of the belt are secured in the belt clamps on the acrylic plate. Cut the belt such that there are 4-5 cms of free end from the belt clamps and enough for the x axis.

